

عربي

**MAXXANA**

Heavy-Duty Beverage & Sanitary Pump

Shanley Pump  
& Equipment, Inc.



# MAXANA

## Features

The Hilge Maxana single stage end suction centrifugal pumps for the Beverage Industry are manufactured in 316Ti rolled stainless steel for durability and long life in Clean-In-Place pumping applications from 0-546 GPM at temperatures up to 302°F up to 449 feet of head.

## Description

Hilge Pumps are designed to cope with media with unique physical and chemical characteristics and are generally used as return scavenging pumps in the beverage and food production industry.

Due to their design, centrifugal pumps cannot vent the suction line when started up, meaning that they cannot initially draw up the media themselves. You must either arrange suction pipe work so that the fluid falls under gravity from a vessel above the pump or fill the pump and the suction line with fluid before starting it. In addition, centrifugal pumps are even more sensitive to air pockets or bubbles in the media, which can lead to a breakdown if air pockets collect in the impeller channels.

Available in close coupled or bare shaft foot mountings makes the Maxana series very versatile in its setup for use. The Maxana series impellers come standard in a shrouded design. Flange mounts are ANSI or DIN standard for ease in hookup.



**Shanley Pump & Equipment, Inc.**  
 2525 S. Clearbrook Drive  
 Arlington Heights, IL 60005  
**P:** 847.439.9200  
**F:** 847.439.9388  
 www.shanleypump.com  
 sales@shanleypump.com

## Usage

The HILGE MAXA Series is an ideal single-stage design with heavy-duty stainless steel construction for use in brew-house brewing operations, beer filtration, dairy and food processing, UF filtration systems and brine pumping applications.

The Maxana series shaft seal is available in either single or double mechanical configuration based off of your needs. Due to quality state of the art manufacturing processes, the Maxana series are a competitively priced centrifugal pumping system that's ideal for heavy duty applications.

## Main Applications

-  Beer Pumping
-  Beverage Pumping
-  Filtration Pumping
-  Food Processing Pumping
-  Recirculation Pumping Applications
-  Filtration Pumping Applications
-  CIP (Clean In Place) Pumping Applications

**GPM** 0 - 546 GPM

**PSI** up to 145 PSI

**TEMP** +302°F

**HEAD** 449 ft.

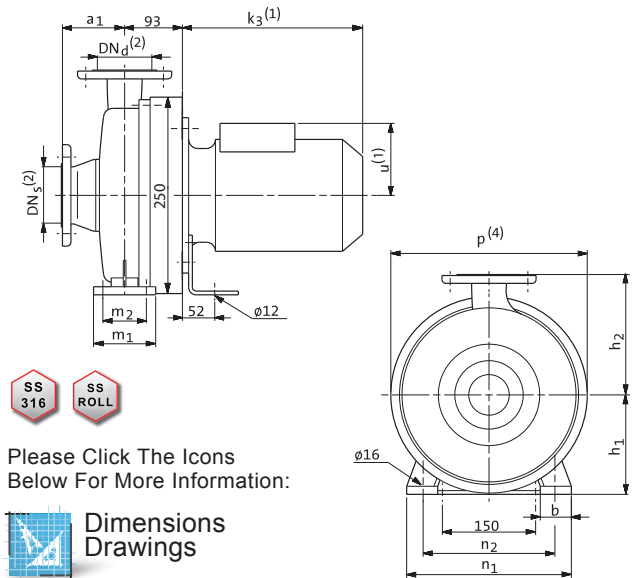

**50HZ Performance Curve**

1450 RPM Performance Curve

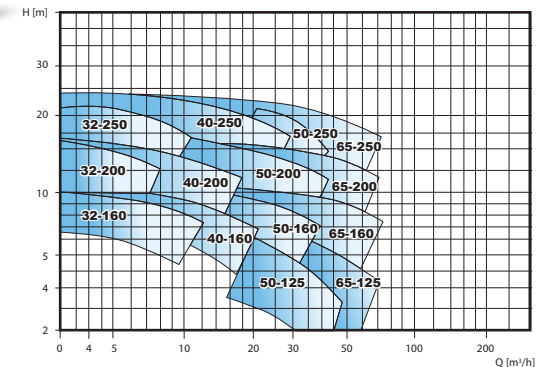

2900 RPM Performance Curve

